

PARTS LIST

Note: QTY is related to one Subassy only, not the entire project.

ITEM	PART NUMBE	TITLE	DESCRIPTION	QTY
1	BSR-302	Pin	Railing Pin	1
2	BSR-306	Plate	4 x 4 Mounting Plate	1
3	BSR-324	Post	1-1/2 x 1-1/2 Post - Longer	1

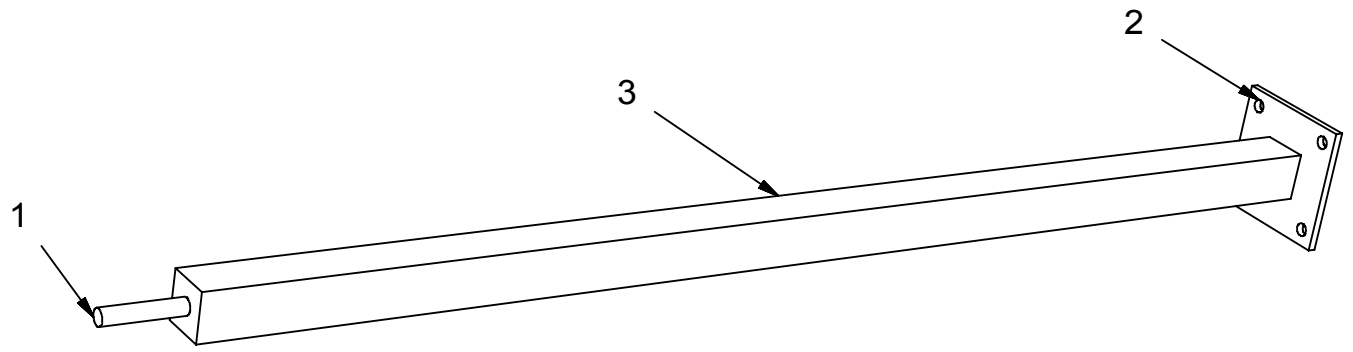
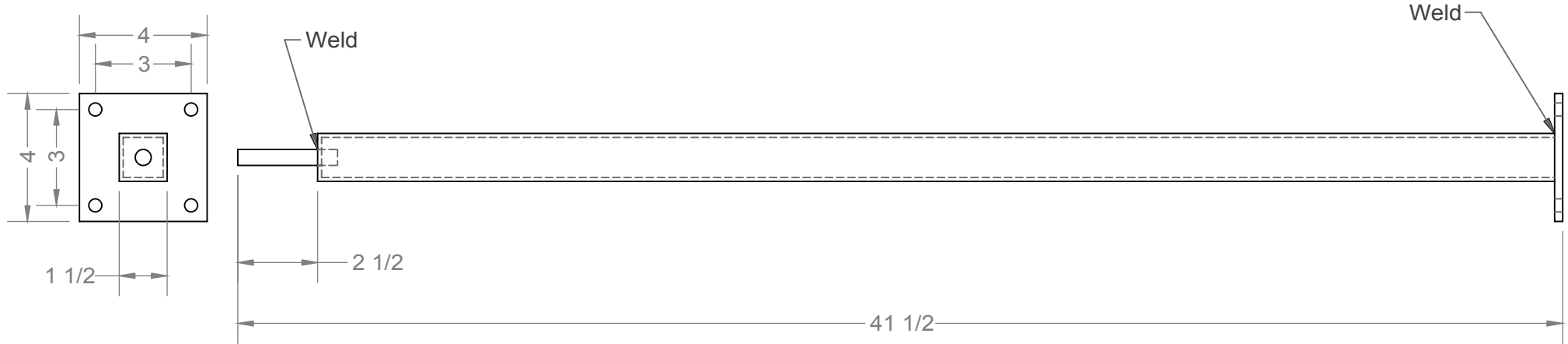

IGNAC BLACKSMITH INC.
ART METAL STUDIO
Mississauga, Ontario, Canada

© 2004 IGNAC BLACKSMITH INC.
THIS DRAWING CONTAINS PROPRIETARY INFORMATION AND SHALL NOT BE USED IN ANY MANNER WITHOUT EXPRESS PERMISSION OF IGNAC BLACKSMITH CORPORATION OR ITS CLIENTS

DRAWN BY: IdealTech
DESIGN BY: IGNAC BLACKSMITH INC.
CHECKED BY: IGNAC BLACKSMITH INC.
APPROVED BY: IGNAC BLACKSMITH INC.
SCALE: As Indicated
DATE: 10/27/2004

TOLERANCES
Decimals:
x.xxxx 0.0005
x.xxx 0.005
x.xx 0.010
x.x 0.1"
Unless Otherwise Noted

Title:	Post Weldment	Entire Project Qty:
Description:	Post Weldment - Longer	Sheet 1 of 1
Project:	Building Stairs Railing (BSR)	BSR-033