

Not Approved for Production!
(Verify dimensions before release)

ITEM	PART No.	DESCRIPTION	QTY.
1	IHZ-227	Mntg. Plate	1
2	IHZ-236	Post	1
3	IHZ-011		2
4	IHZ-012		2

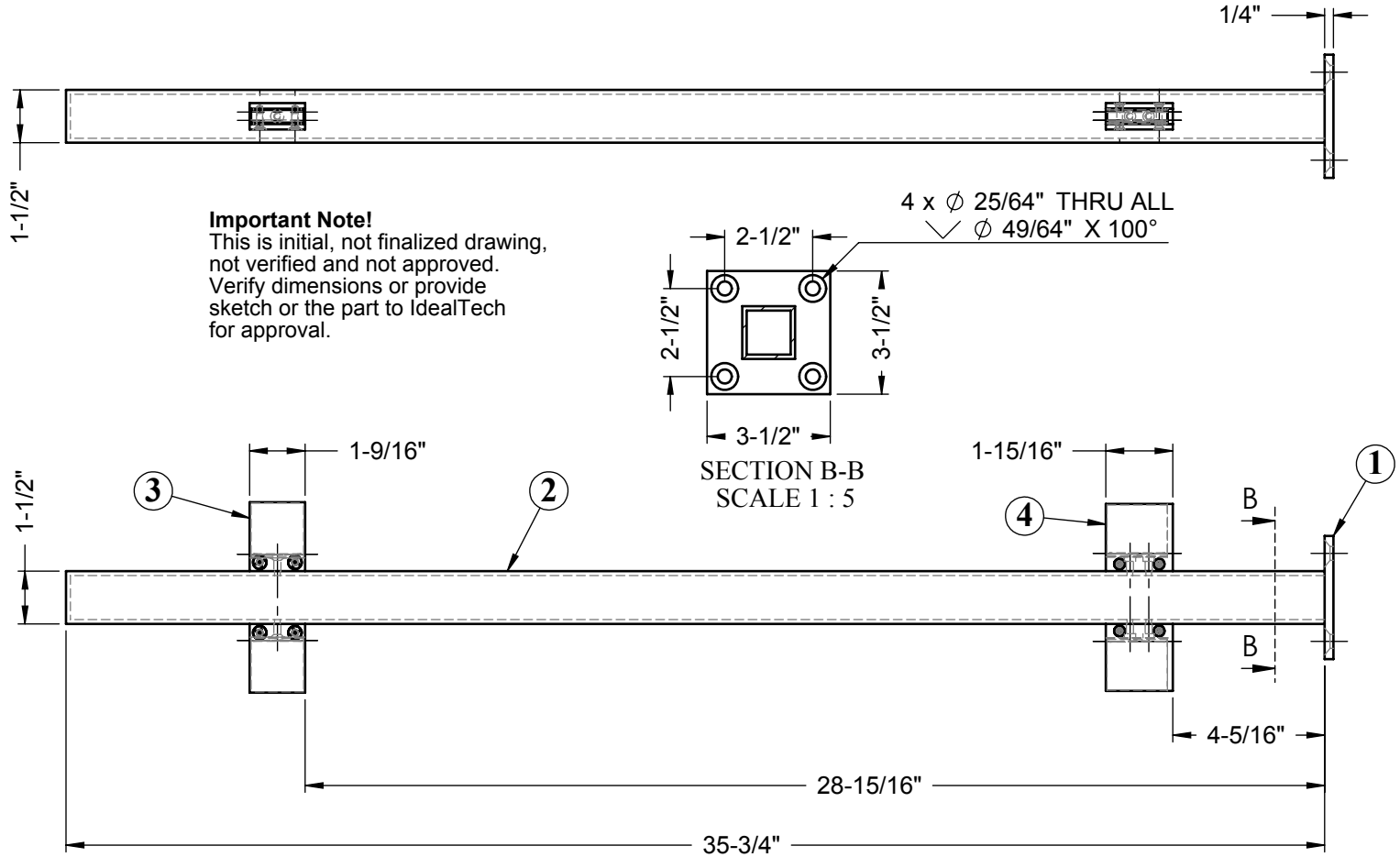
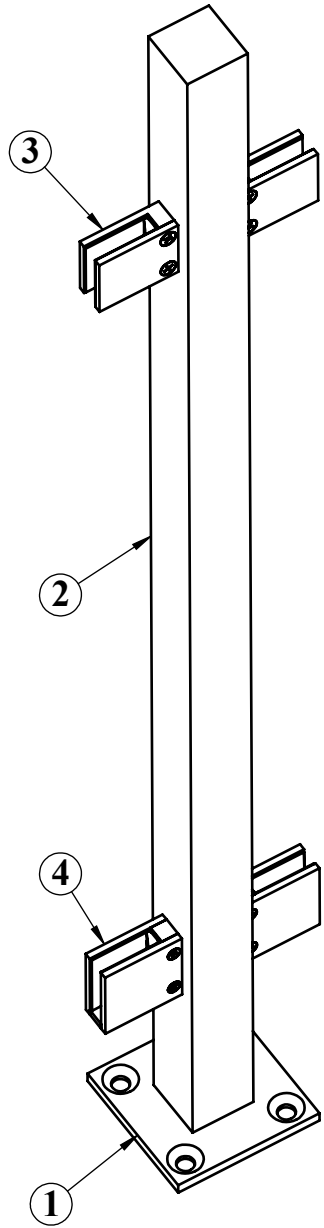

IGNAC BLACKSMITH INC Metal Art Studio Tel: 605.273.5561 Fax: 905.273.5562 www.ignacblacksmith.com info@ignacblacksmith.com	Drawn: IdealTech	TOLERANCES Decimals: x.xxxx 0.0005" x.xxx 0.005" x.xx 0.01" x.x 0.1" Unless otherwise specified dimensions are in inches	Description:	QTY Subassy Total
	Checked: ---		Material:	
	Approved: ---		Finish/Notes:	Sheet 1 of 1
	Design: ---		Created: ---	SCALE: 1:10
	SIZE A			